

Comfort series
15 mm embeddable

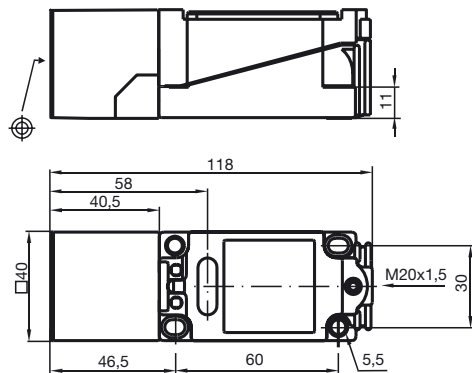

CE 0102

| General specifications | |
|----------------------------------|--------------------------------|
| Switching element function | NAMUR NC |
| Rated operating distance s_n | 15 mm |
| Installation | embeddable |
| Assured operating distance s_a | 0 ... 12.15 mm |
| Reduction factor r_{Al} | 0.4 |
| Reduction factor r_{Cu} | 0.3 |
| Reduction factor r_{V2A} | 0.85 |
| Nominal ratings | |
| Nominal voltage U_o | 8 V |
| Switching frequency f | 0 ... 150 Hz |
| Current consumption | |
| Measuring plate not detected | ≥ 3 mA |
| Measuring plate detected | ≤ 1 mA |
| Standard conformity | |
| EMC in accordance with | IEC / EN 60947-5-2:2004 |
| Standards | DIN EN 60947-5-6 (NAMUR) |
| Ambient conditions | |
| Ambient temperature | -25 ... 100 °C (248 ... 373 K) |
| Mechanical specifications | |
| Connection type | terminal compartment |
| Core cross-section | up to 2.5 mm ² |
| Housing material | PBT |
| Sensing face | PBT |
| Protection degree | IP68 |
| General information | |
| Use in the hazardous area | see instruction manuals |
| Category | 1G; 2G; 1D |

Connection type:

N / NO

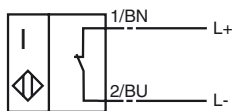

ATEX 1G

Instruction

Device category 1G

Directive conformity

Standard conformity

CE symbol

Ex-identification

EC-Type Examination Certificate

Appropriate type

Effective internal capacitance C_i

Effective internal inductance L_i

General

Highest permissible ambient temperature

Installation, Commissioning

Maintenance

Special conditions

Protection from mechanical danger

Electrostatic charging

Manual electrical apparatus for hazardous areas

for use in hazardous areas with gas, vapour and mist

94/9/EG

EN 50014:1997; EN 50020:1994; EN 50284:1999

Ignition protection "Intrinsic safety"

Use is restricted to the following stated conditions

CE 0102

Ex II 1G EEx ia IIC T6

PTB 00 ATEX 2048 X

NJ 15+U.+N...

≤ 140 nF ; a cable length of 10 m is considered.

≤ 130 μ H ; a cable length of 10 m is considered.

The apparatus has to be operated according to the appropriate data in the data sheet and in this instruction manual.

The EU prototype test certificate must be observed. The special conditions must be adhered to!

The temperature ranges, according to temperature class, are given in the EU prototype test certificate. Note: Use the temperature table for category 1 !!! The 20 % reduction in accordance with EN 1127-1:1997 has already been accounted for in the temperature table for category 1.

Laws and/or regulations and standards governing the use or intended usage goal must be observed.

The intrinsic safety is only assured in connection with an appropriate related apparatus and according to the proof of intrinsic safety.

The associated apparatus must satisfy the requirements of category ia.

Due to the possible danger of ignition, which can arise due to faults and/or transient currents in the equipotential bonding system, galvanic isolation of the power supply and signal circuit is preferable. Associated apparatus without electrical isolation must only be used if the appropriate requirements of IEC 60079-14 are met.

No changes can be made to apparatus, which are operated in hazardous areas. Repairs to these apparatus are not possible.

When used in the temperature range below -20°C the sensor should be protected from knocks by the provision of an additional housing.

When used in group IIC non-permissible electrostatic charges should be avoided on the plastic housing parts.

ATEX 2G

Instruction

Device category 2G

Directive conformity

Standard conformity

CE symbol

Ex-identification

EC-Type Examination Certificate

Appropriate type

Effective internal capacitance C_i

Effective internal inductance L_i

General

Highest permissible ambient temperature

Installation, Commissioning

Maintenance

Special conditions

Protection from mechanical danger

Manual electrical apparatus for hazardous areas

for use in hazardous areas with gas, vapour and mist
94/9/EG

EN 50014:1997, EN 50020:1994

Ignition protection "Intrinsic safety"

Use is restricted to the following stated conditions

CE 0102

Ex II 1G EEx ia IIC T6

PTB 00 ATEX 2032 X

NJ 15+U.+N...

≤ 140 nF ; a cable length of 10 m is considered.

≤ 130 μ H ; a cable length of 10 m is considered.

The apparatus has to be operated according to the appropriate data in the data sheet and in this instruction manual. The EU prototype test certificate must be observed. The special conditions must be adhered to!

The temperature ranges, according to temperature class, are given in the EU prototype test certificate.

Laws and/or regulations and standards governing the use or intended usage goal must be observed. The intrinsic safety is only assured in connection with an appropriate related apparatus and according to the proof of intrinsic safety.

No changes can be made to apparatus, which are operated in hazardous areas. Repairs to these apparatus are not possible.

When used in the temperature range below -20°C the sensor should be protected from knocks by the provision of an additional housing.

ATEX 1D

Instruction

Device category 1D

Directive conformity

Standard conformity

CE symbol

Ex-identification

EC-Type Examination Certificate

Appropriate type

Effective internal capacitance C_i

Effective internal inductance L_i

General

Maximum housing surface temperature

Installation, Commissioning

Maintenance

[Fett]Special conditions

Electrostatic charging

Manual electrical apparatus for hazardous areas

for use in hazardous areas with combustible dust

94/9/EG

IEC 61241-11:2002: draft; prEN61241-0:2002

type of protection intrinsic safety "iD"

Use is restricted to the following stated conditions

CE 0102

Ex II 1D Ex iaD 20 T 108 °C (381 K)

ZELM 03 ATEX 0128 X

NJ15+U..-N..

≤ 140 nF ; a cable length of 10 m is considered.

≤ 130 μH ; a cable length of 10 m is considered.

The apparatus has to be operated according to the appropriate data in the data sheet and in this instruction manual.

The EU prototype test certificate must be observed.

The special conditions must be adhered to!

The maximum surface temperature of the housing is given in the EC-Type Examination Certificate.

Laws and/or regulations and standards governing the use or intended usage goal must be observed.

The intrinsic safety is only assured in connection with an appropriate related apparatus and according to the proof of intrinsic safety.

The associated apparatus must satisfy at least the requirements of category ia IIB or iaD. Because of the possibility of the danger of ignition, which can arise due to faults and/or transient currents in the equipotential bonding system, galvanic isolation in the power supply and signal circuits is preferable. Associated apparatus without electrical isolation must only be used if the appropriate requirements of IEC 60079-14 are met.

The intrinsically safe circuit has to be protected against influences due to lightning.

When used in the isolating wall between Zone 20 and Zone 21 or Zone 21 und Zone 22 the sensor must not be exposed to any mechanical danger and must be sealed in such a way, that the protective function of the isolating wall is not impaired. The applicable directives and standards must be observed.

No changes can be made to apparatus, which are operated in hazardous areas. Repairs to these apparatus are not possible.

Electrostatic charging due to the flow of media during operation must be excluded.

This can be achieved by limiting the surface area of the plastic housing exposed to the electrostatic charging to less than 100 cm².